

NOMADICARK

SUPPLIER OF QUALITY PRODUCTS TO
PROFESSIONAL RV / MOTORHOME BUILDERS

FRIDGES



ADDRESS

3404 MANGROVE AVE,
NORFOLK
VA 23502



EMAIL

US@NOMADICARK.COM



TELEPHONE

(+1) 757 201 0016



NomadicArk.com

COMPACT COOLING

BIG EFFICIENCY

ALWAYS.

Introducing the NomadicArk compact refrigerator range, designed specifically for motorhome and leisure industry use. We've pooled our years of experience to combine all the features the end consumer could want into an adaptable range of 20L – 130L capacity units.

Designed for 12V / 24V DC vehicle systems our fridges are engineered with cutting-edge LG compressor technology ensures optimal cooling performance while consuming minimal energy. Its sleek gloss black exterior houses a versatile interior layout, maximising on storage without compromising on the performance synonymous with all NomadicArk products.



FLEXIBLE CONFIGURATION

Removable freezer section, door bins and crisping drawer.

SMART LOCKING DOOR LATCH

Preventing accidental opening in transit.

RUGGED & STRONG BUILD QUALITY

Shockproof by design, and able to cope with temperatures upto 45°C.

DIGITAL DISPLAY

Set fridge temperatures or power modes with ease.

SIMPLE INSTALLATION, EASY MAINTENANCE

Just a two wire install with pre-wired fuse. Replaceable rubber door seal.



REVERSIBLE DOOR HINGE

Fridge door fronts can be hung on the left or right with a simple two-screw clip-out and switch process. This gives maximum flexibility within the kitchen layout for placement and use of the fridge.



LOW NOISE LEVELS

The compressor only runs when the fridge needs to cool, and then it shuts off. Even when running this is at most only 45dB, and typically much lower.

LEADING PERFORMANCE

With an LG compressor and brushless DC fan, each fridge delivers superior cooling while remaining ultra-quiet in operation.

This durable design reduces performance issues over the product's lifetime, while fast cooling allows operation from -20°C to +20°C.



SAFETY & EFFICIENCY

A three-stage battery protection system is built into every fridge to ensure the vehicle battery is never compromised by the fridge operation. This can also be adjusted via our app.

Choose between ECO mode for energy-saving operation and MAX mode for faster cooling, with intelligently cycling to maintain efficiency.

VEHICLE READY

Purpose-built with a dual-voltage 12V/24V DC compressor, engineered to run natively off your RV's battery system without the need for a power-hungry inverter.



SIZES

FD20 DRAWER [NA-FD20 B]

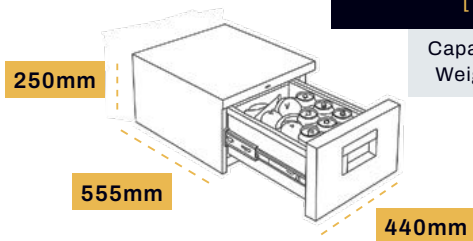

Capacity (net) 13.2L
Weight (net) 16.8kg

FD30 DRAWER [NA-FD30 B]

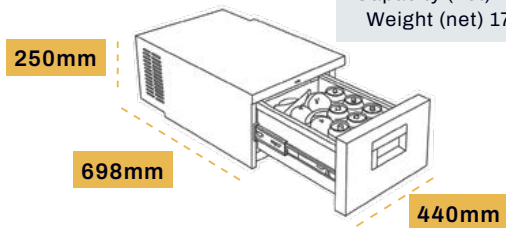

Capacity (net) 20.5L
Weight (net) 17.4kg

F50 FRIDGE [NA-F50LG]

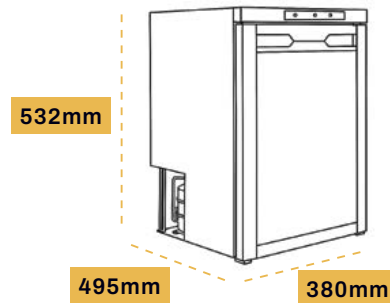

Capacity (net) 43.4L
Weight (net) 16.8kg

F90 FRIDGE [NA-F90LG]



Capacity (net) 93L
Weight (net) 16.8kg

F65 FRIDGE [NA-F65LG]

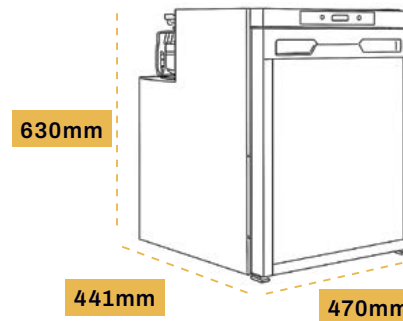

Capacity (net) 58L
Weight (net) 16.8kg

F85 FRIDGE [NA-F85LG]

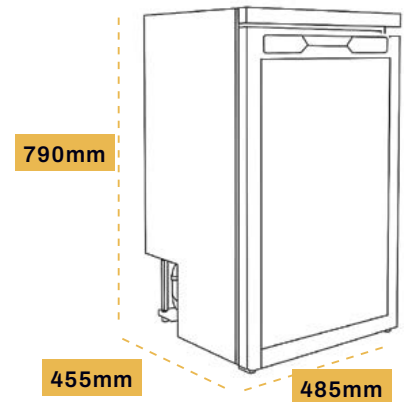

Capacity (net) 13.2L
Weight (net) 16.8kg

F130 FRIDGE [NA-F130LG]

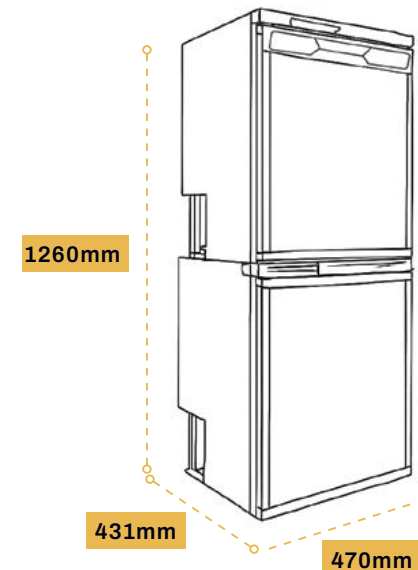

Capacity (net) 116L
Weight (net) 16.8kg

STAY IN THE KNOW

View more images of the full range on our website.

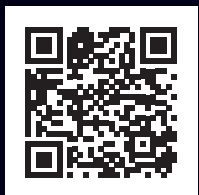

www.nomadicark.com

* All sizes are the minimum install dimensions

IN COMPLETE CONTROL

FEATURES NOT AVAILABLE ELSEWHERE

Each fridge is equipped with built-in Bluetooth connectivity and our exclusive NomadicArk App – a standout feature your customers will really appreciate. Whether they're relaxing inside their campervan or sitting outside enjoying the view, they can monitor and control fridge settings directly from their phone.

While app control is becoming more common, the NomadicArk system sets itself apart with an intuitive interface and intelligent features that make it easier for your customers to manage their cooling on the go – giving you a unique selling point in a competitive market.

TEMPERATURE CONTROL

Adjust fridge and freezer set-points. Keep track of the fridge temperature while you travel..

POWER MANAGEMENT

Check the source, levels and protection.

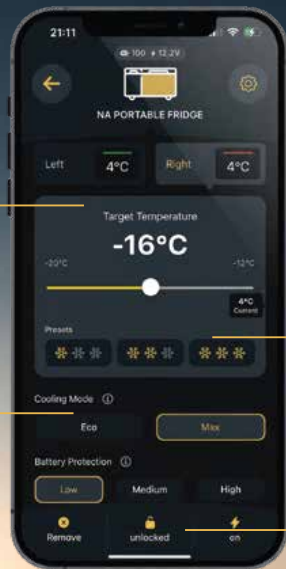

MODE SELECTION

Presets to allow for quick and easy one-press setup.

EASY USE

Turn the fridge on/off and prevent any unwanted changes with a one-tap lock.



MULTI-UNIT CONTROL

Manage all your NomadicArk appliances from one app. Monitor temperatures, adjust settings, and receive alerts for each unit - all in one place.

APPLIANCE GROUPING

Organise your appliances by vehicle or setup for effortless management. Create custom groups - whether for individual vans, demo units, or customer builds - and view or adjust all linked appliances at once. Ideal for fleet managers, converters, or sellers with multiple vehicles, you can easily switch between units, reassign fridges to new vehicles, or remove them when sold. This makes managing inventory, after-sales support, and customer demonstrations simple and efficient.

COMPRESSOR MAINTENANCE

A few minutes of care helps keep performance!

Clean air vents and grills - Remove dust, lint, or ventilation area using a soft brush or vacuum. C

Check for obstructions - Make sure nothing is blocking the air vents around the fridge.

Check power connections - F

HINTS & TIPS

The app supports you with built-in advice for optimal performance. Receive timely reminders for routine care - like compressor maintenance - to help extend the unit's lifespan and maintain efficiency. These proactive tips not only keep the fridge running smoothly but also reduce the need for after-sales support or troubleshooting.

DOWNLOAD THE APP TODAY



GET IT ON Google Play

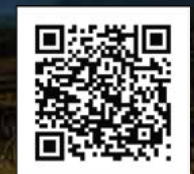

Download on the App Store

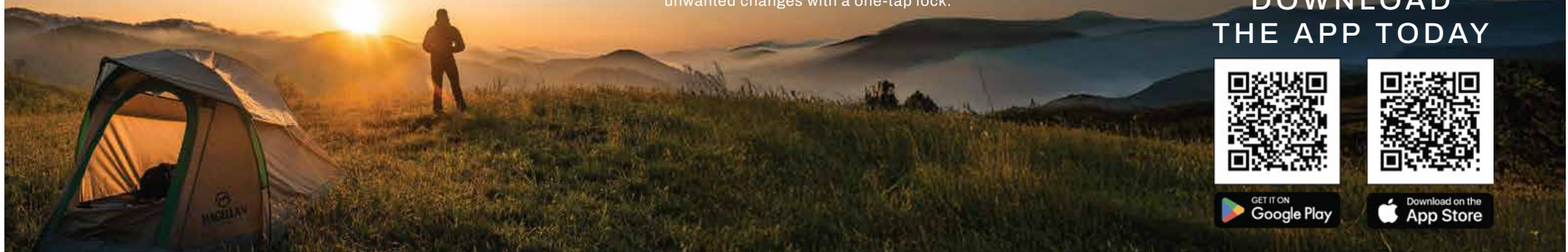

A NEW STANDARD

At NomadicArk we believe in creating experiences that are shaped by the way we live. This is in everything we do.

We've built a wealth of knowledge that we pour into each product to provide the features, quality, compelling experience and value the market demands. Our customer-oriented approach means we pay attention to the smallest details to provide attractive and useful products to the trade conversion market.

The strong B2B partnerships we form incite and inspire our future plans, and we're proud of how this focus fosters customer loyalty and repeat business.

PRODUCT QUALITY

To maintain the NomadicArk brand's reputation for quality, we only source from trusted and professional manufacturers.

RELIABLE SERVICE

Leveraging the needs of a large customer base, we're able to secure exceptional service from our suppliers.

SUPPLIER RELATIONSHIPS

Our team proactively visits suppliers' facilities to assess their control procedures and foster collaboration.

INNOVATIVE SOLUTIONS

Our global reach across diverse markets allows us to combine insights and inspire innovative solutions.

SAFETY STOCKS

We can hold large safety stocks to provide peace of mind and mitigate potential supply chain disruptions.

STRONG ARCHITECTURE

We've made significant investment into our proprietary supply control management systems.

